

AUX - Contatti ausiliari 250 V AC/DC T1-T6 da cablare (3Q+1SY)  
 AUX - Auxiliary contacts 250 V AC/DC T1-T6 to wire (3Q+1SY)  
 AUX - Hilfskontakte 250 V AC/DC T1-T6, zu verdrahten (3Q+1SY)  
 AUX - Contacts auxiliaires 250 V CA/CC T1-T6 à câbler (3Q+1SY)  
 AUX - Contactos auxiliares 250 V CA/CC T1-T6 sin cablear (3Q+1SY)  
 AUX - T1-T6无电缆连线辅助触头250V-24VAC/DC (3合/分闸+1脱扣器脱扣)

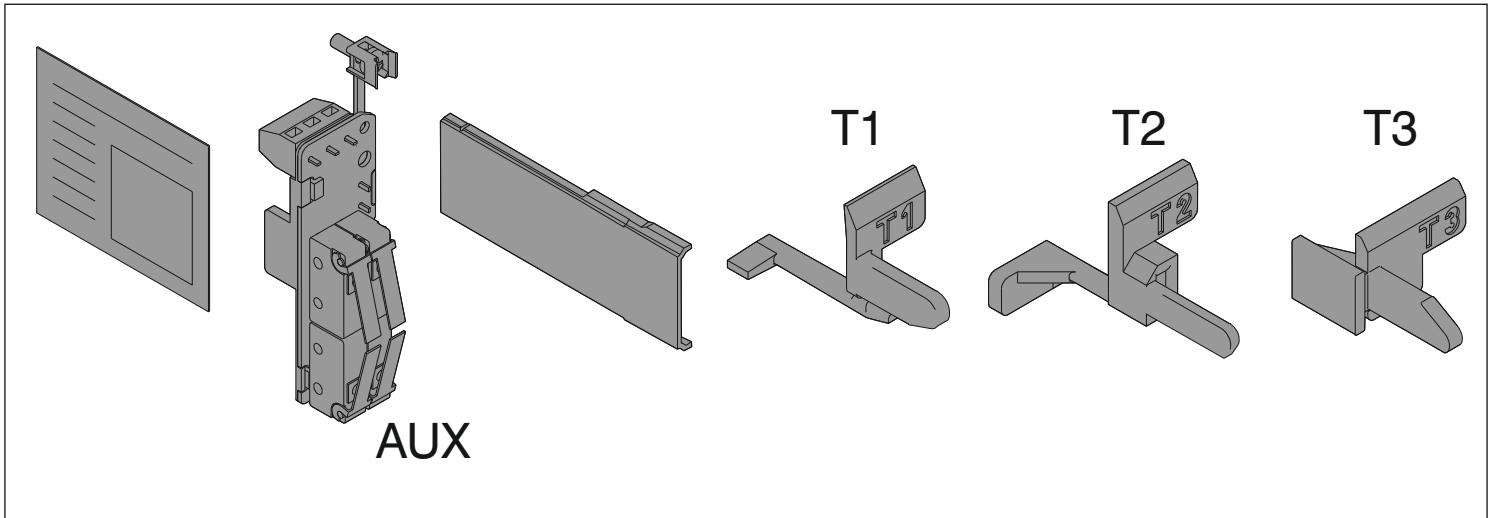

## A

Se gli interruttori T3 sono interbloccati vedere 1SDH000552R0001 oppure 1SDH000553R0001  
 When T3 circuit breakers are interlocked, see 1SDH000552R0001 or 1SDH000553R0001  
 Wenn die Leistungsschalter T3 verriegelt sind, siehe 1SDH000552R0001 bzw. 1SDH000553R0001  
 Si les disjoncteurs T3 sont interverrouillés, voir 1SDH000552R0001 ou 1SDH000553R0001  
 Si los interruptores T3 están enclavados entre sí, véase 1SDH000552R0001 o 1SDH000553R0001  
 当T3断路器被联锁时，请参看 1SDH000552R0001 或 1SDH000553R0001

## B

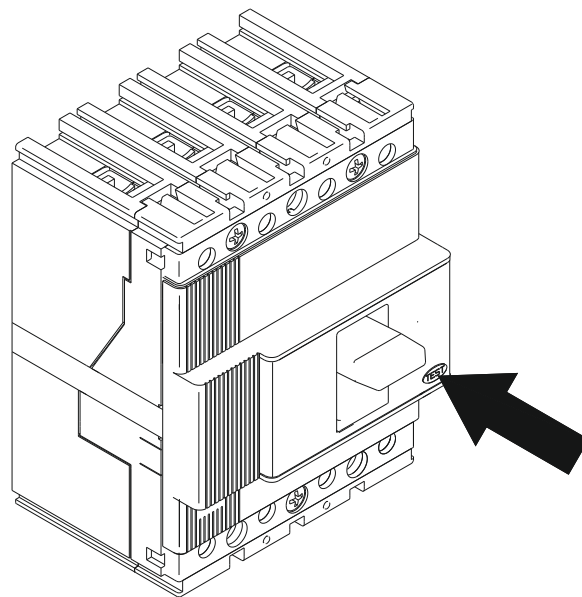

T1-T2-T3  
 T4-T5-T6

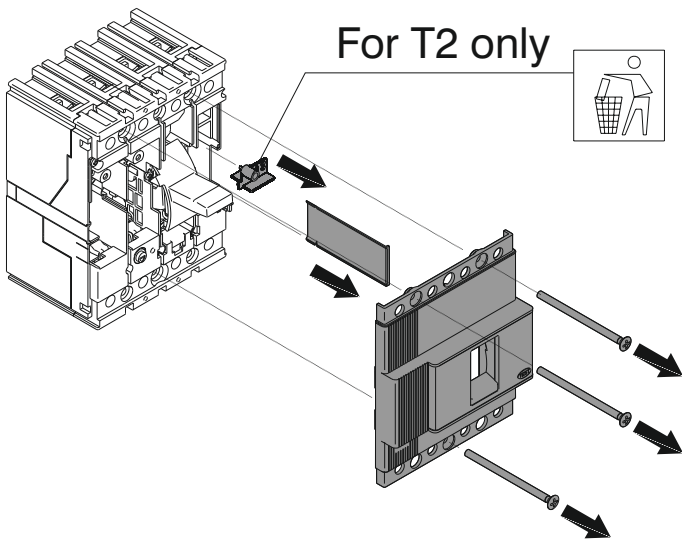
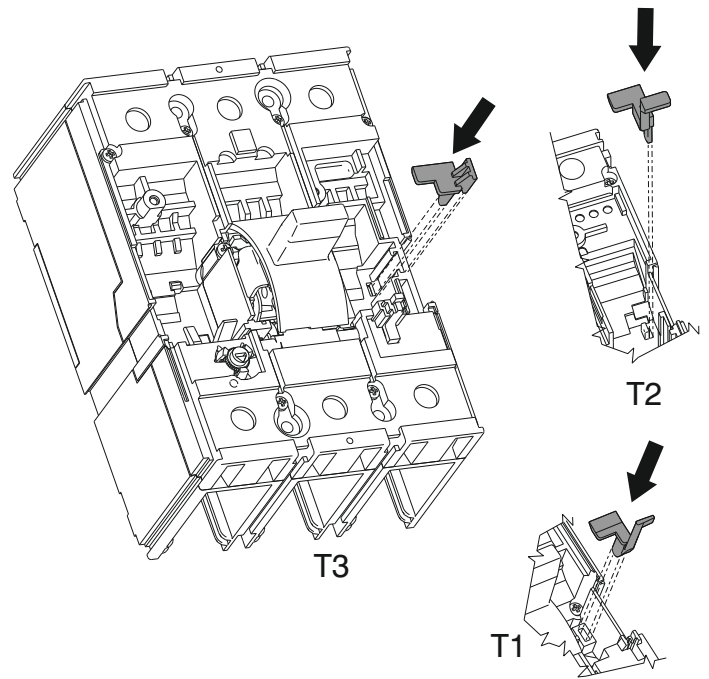
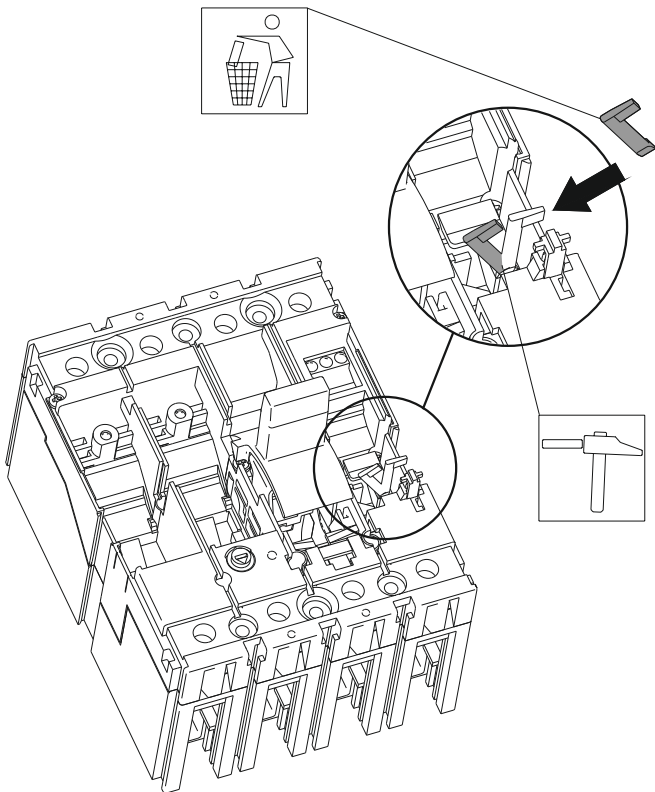
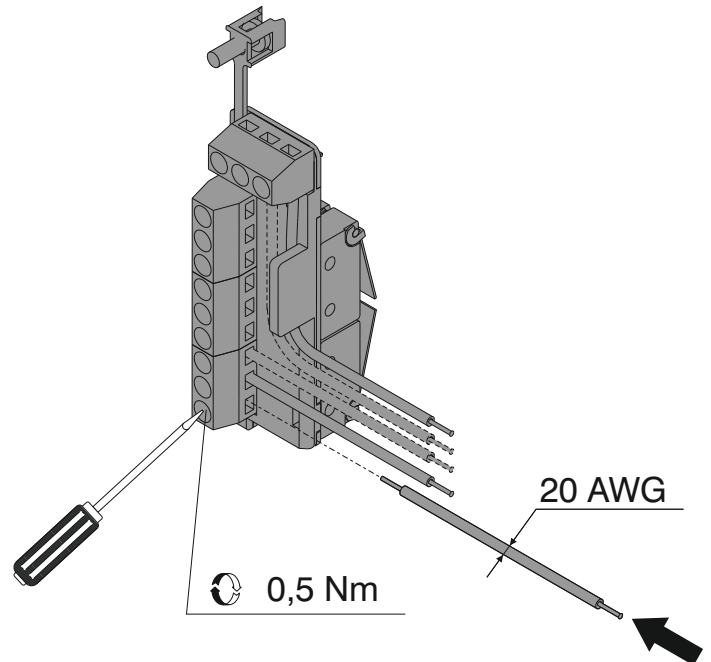
**C****T1-T2-T3****D****T1-T2-T3****E****T1****F****AUX-T1-T2-T3**

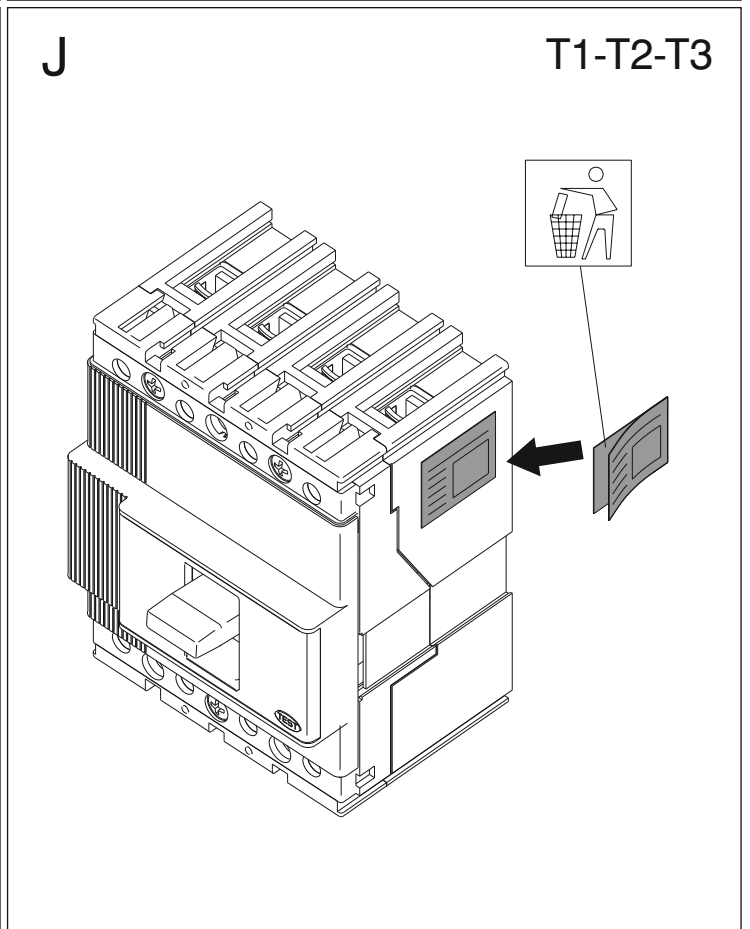
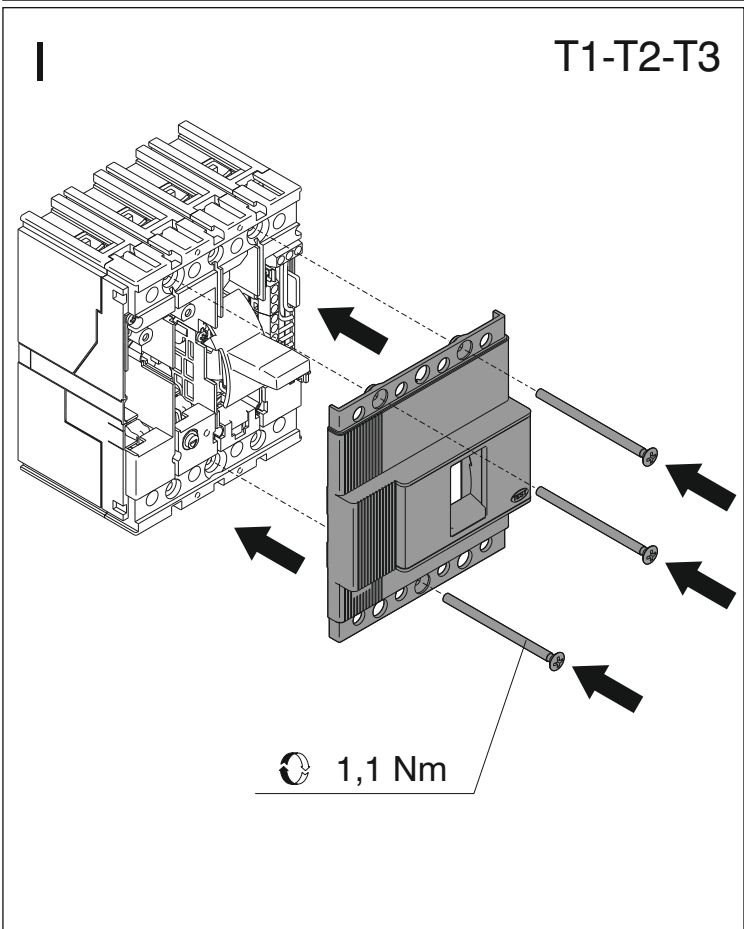
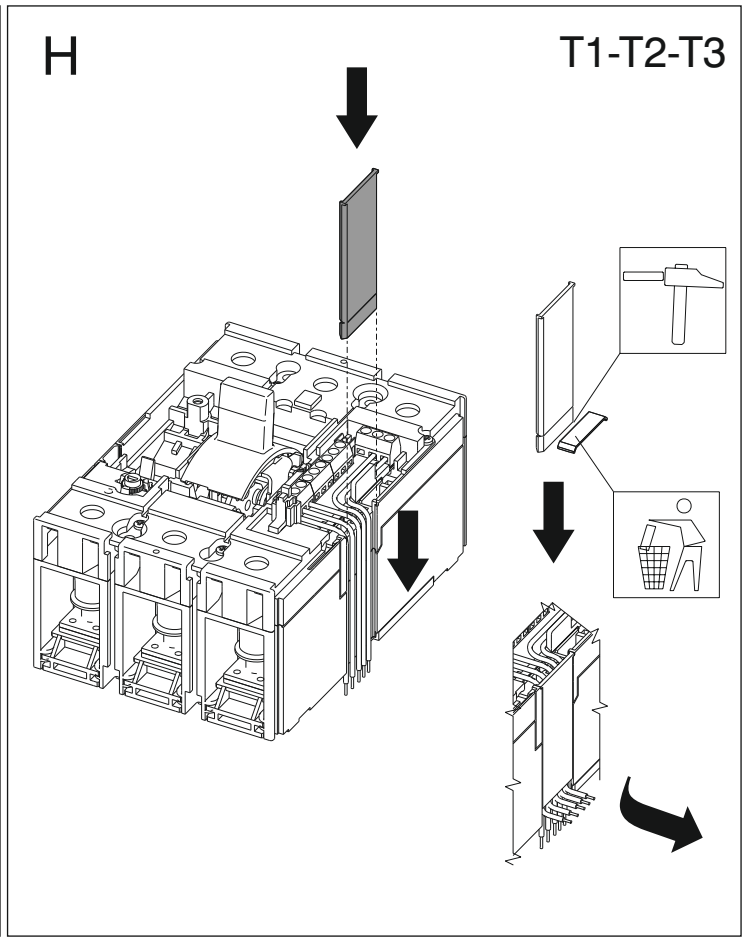
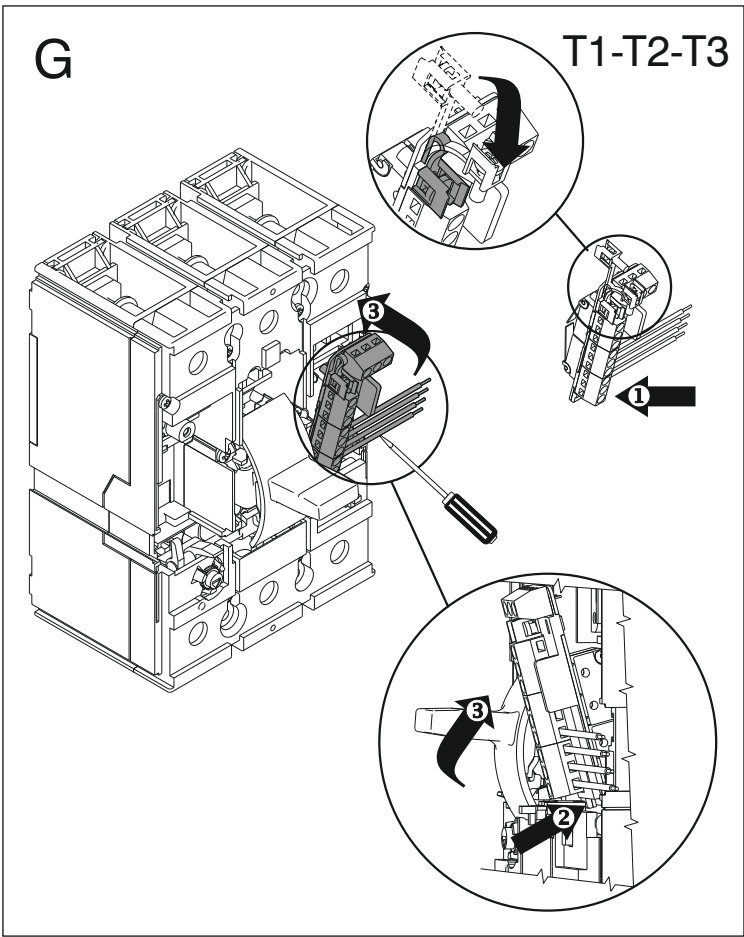

K

T4-T5-T6

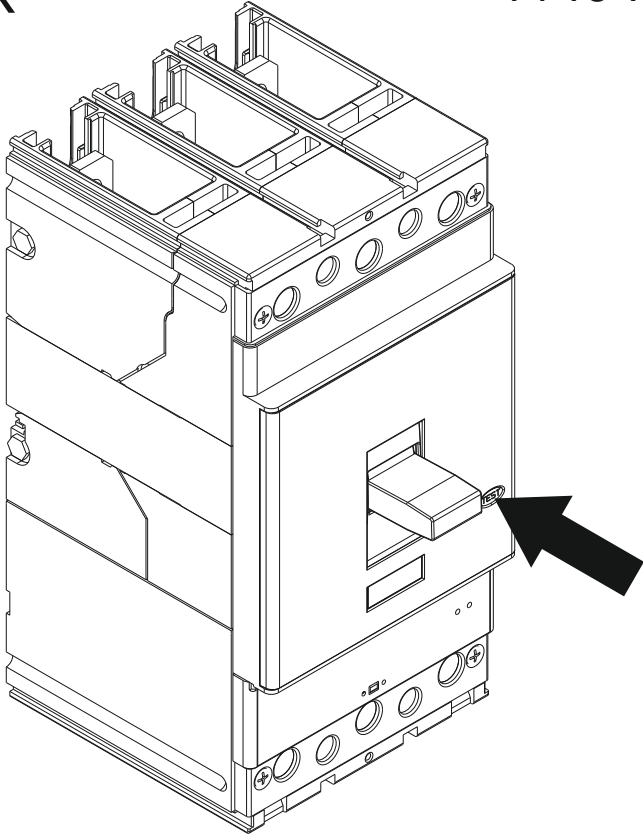

L

T4-T5

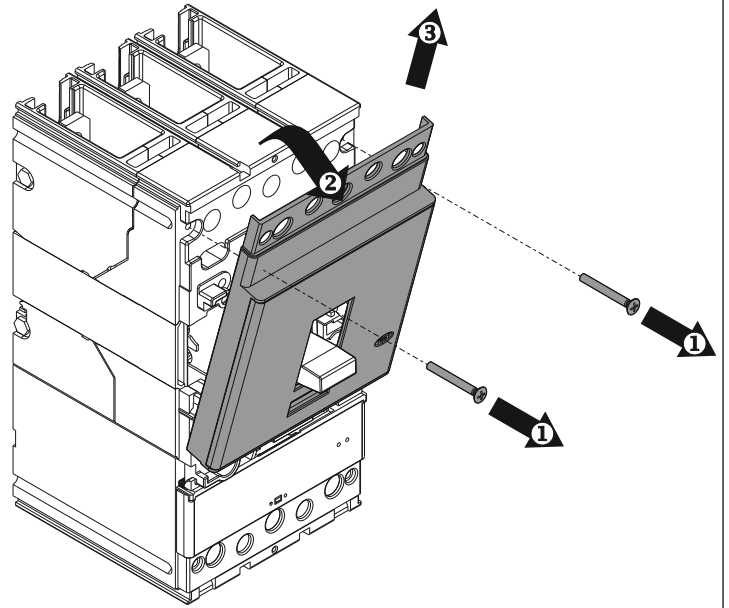

M

T4-T5

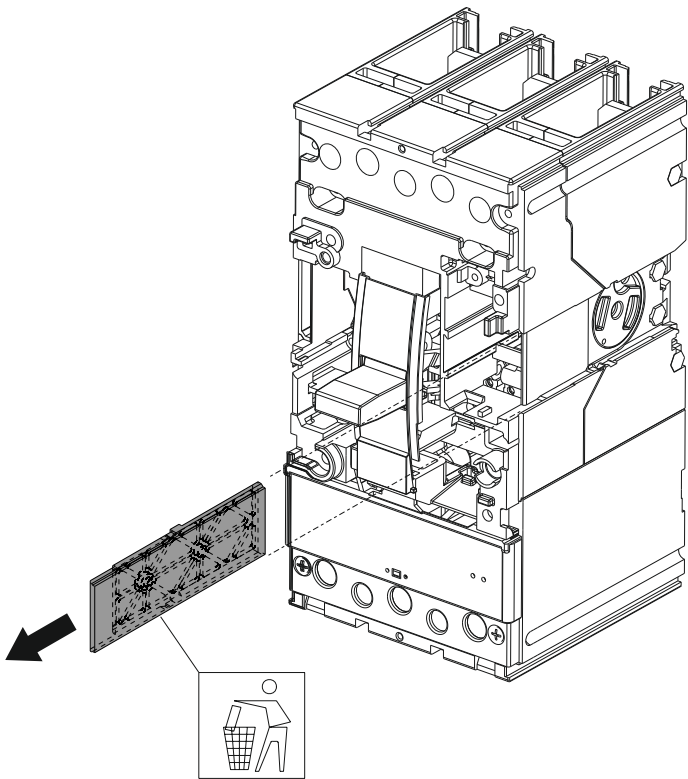

N

AUX-T4-T5

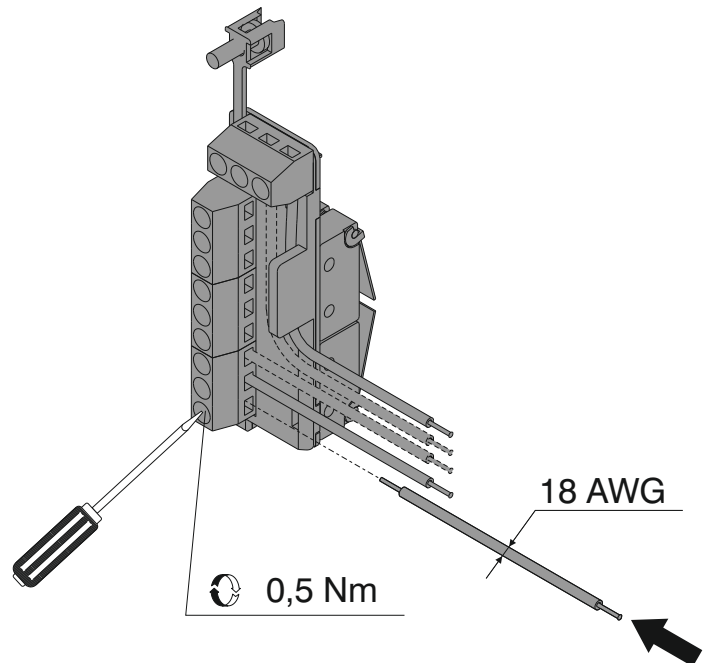

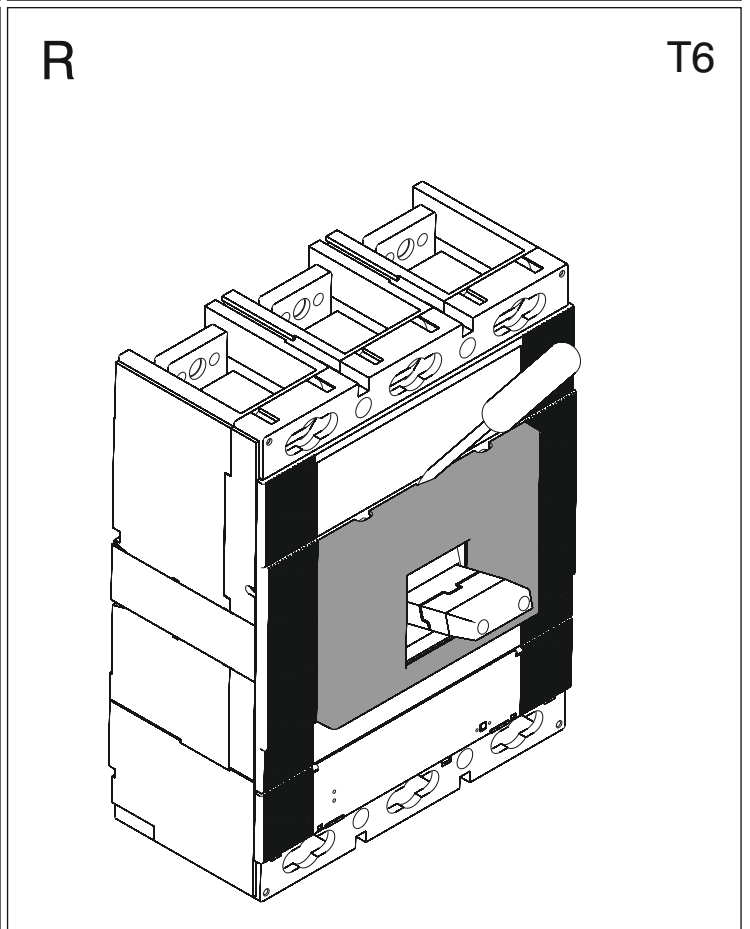
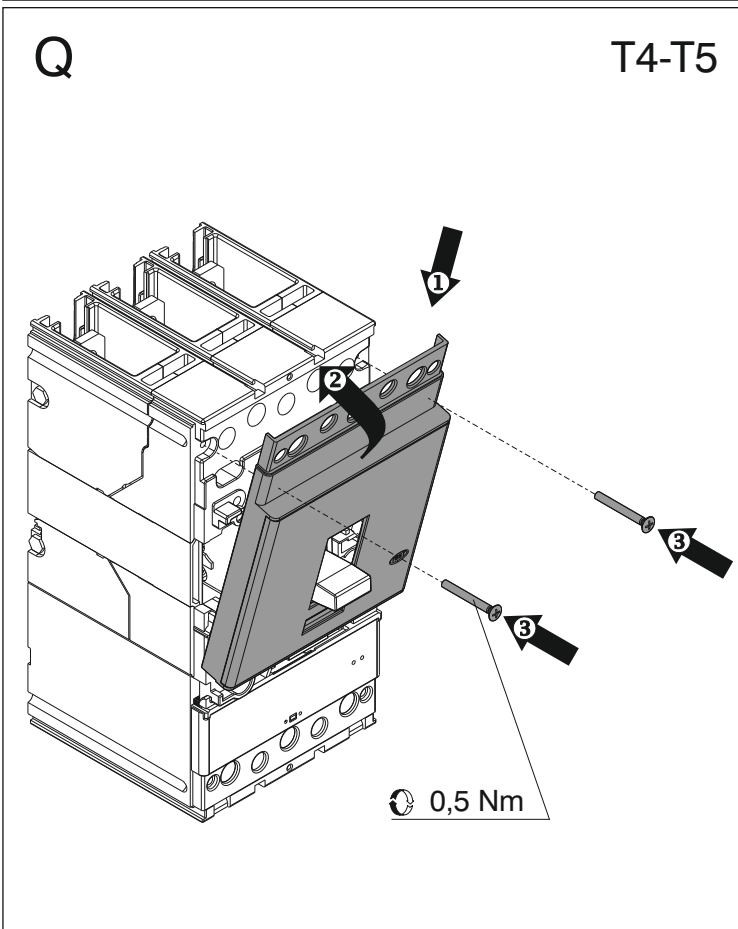
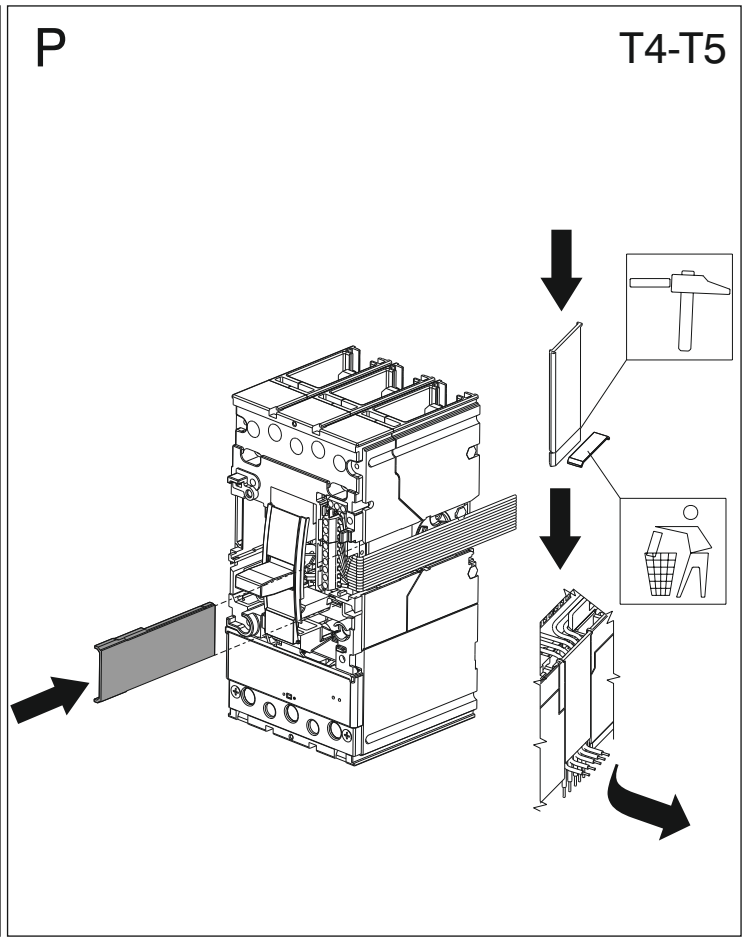
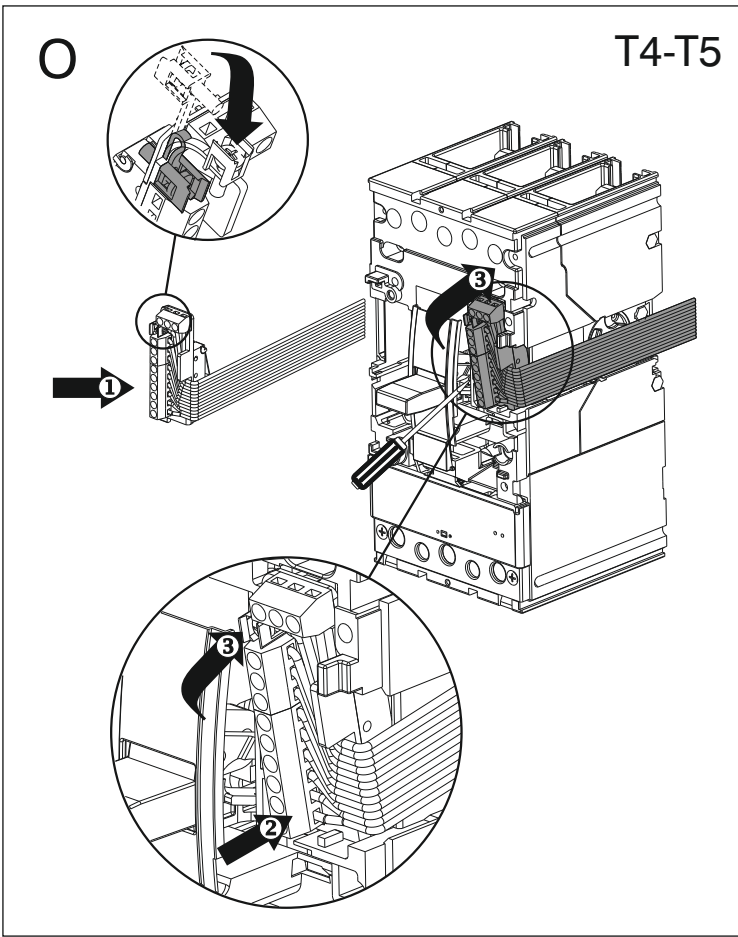

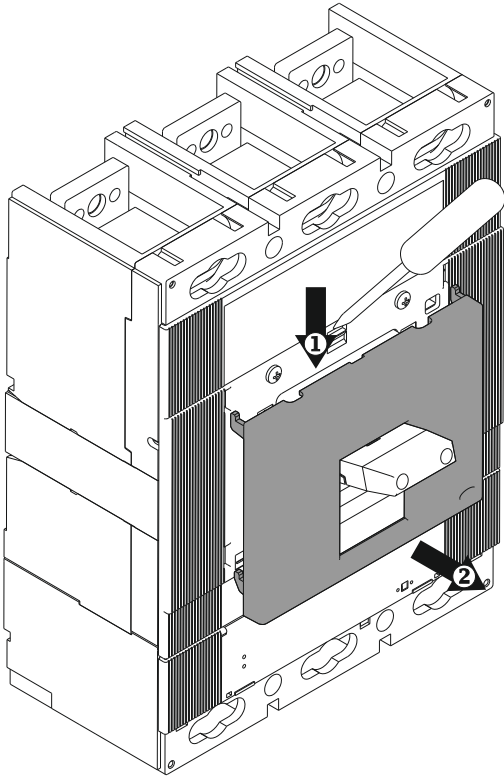
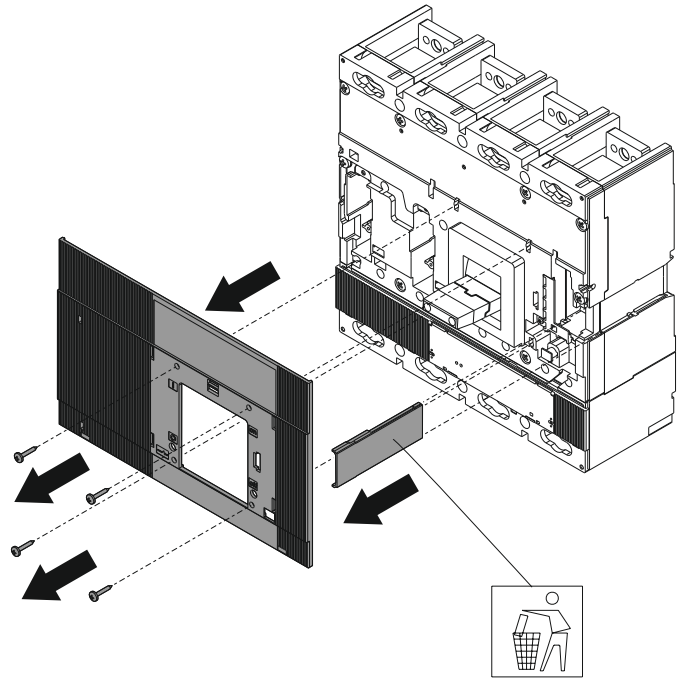
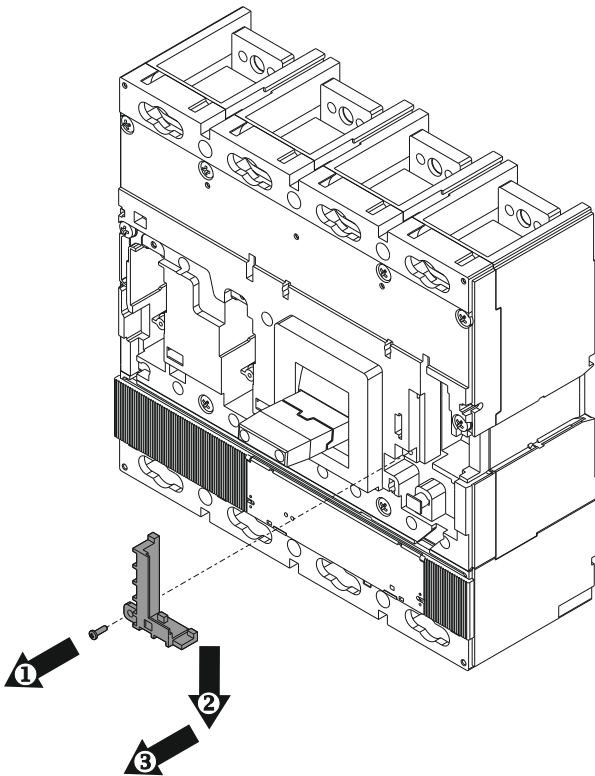
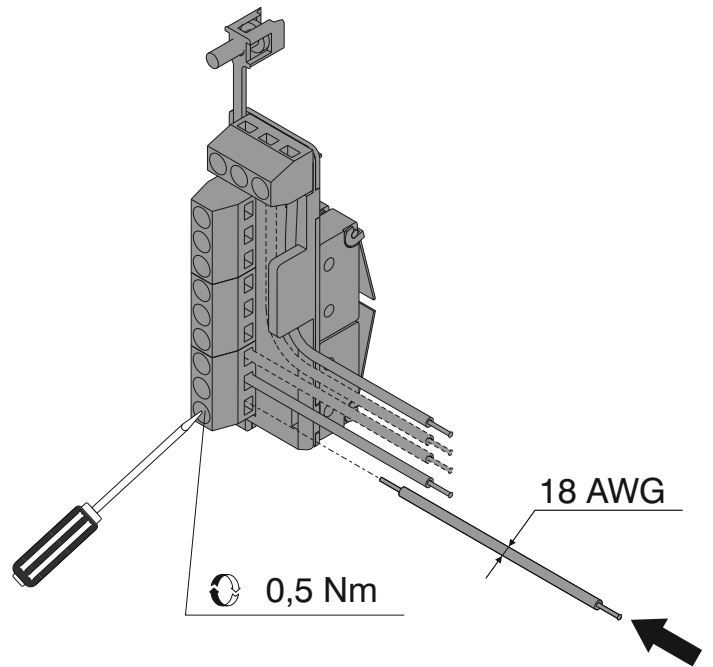
**S****T6****T****T6****U****T6****V****AUX-T6**

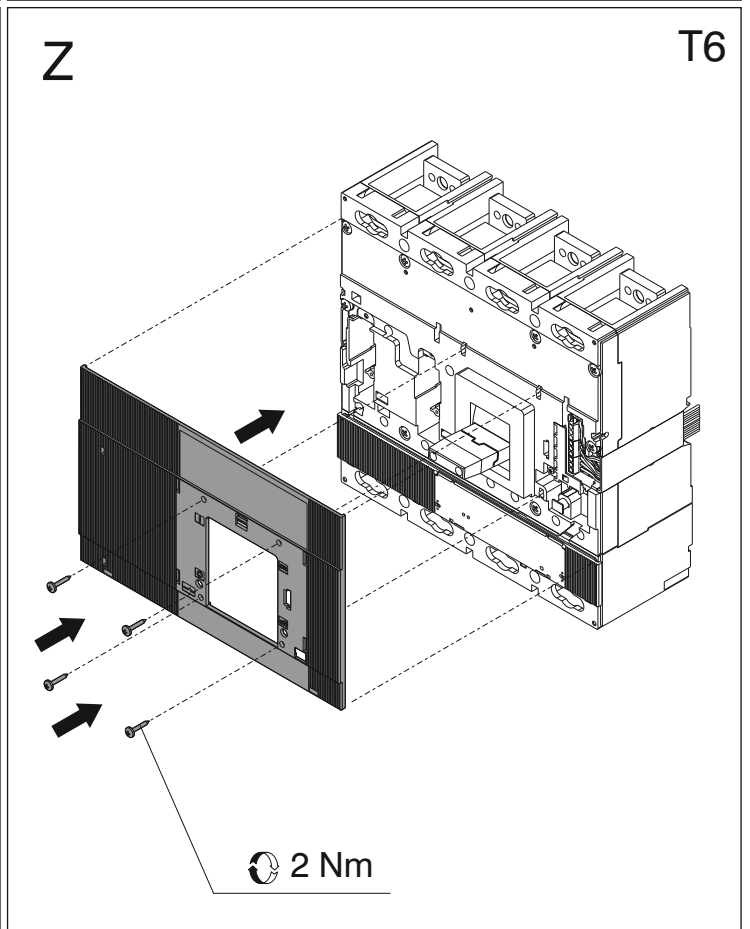
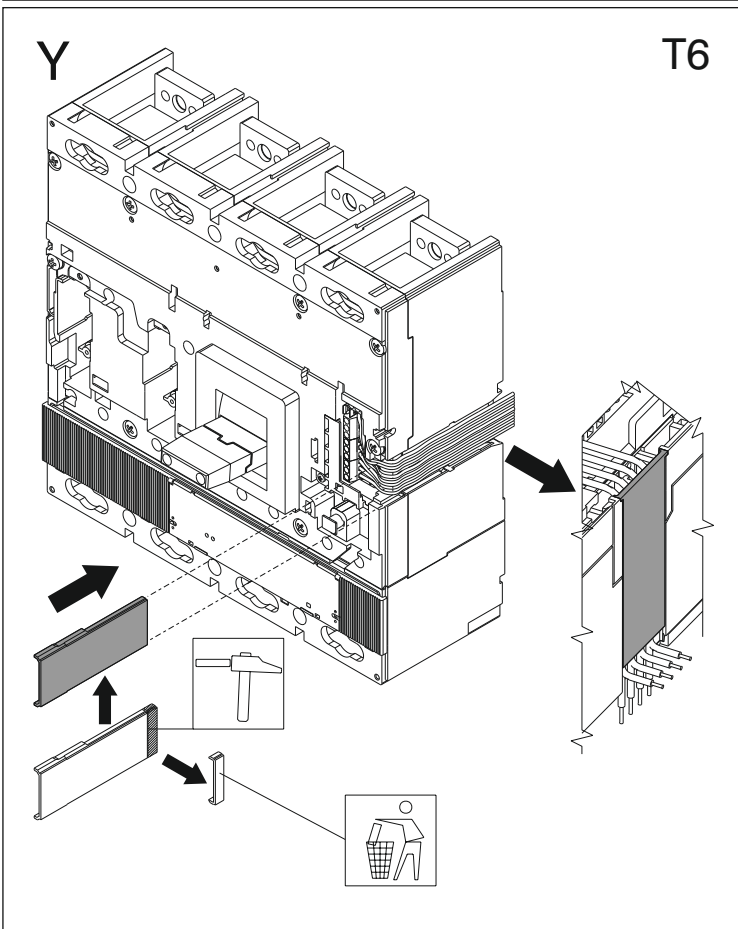
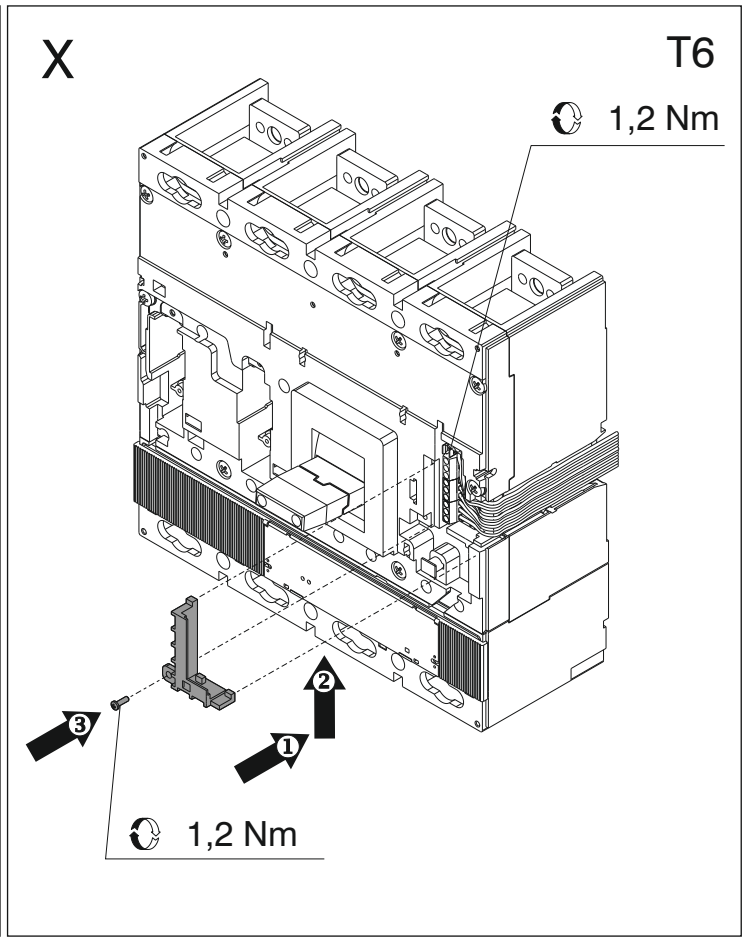
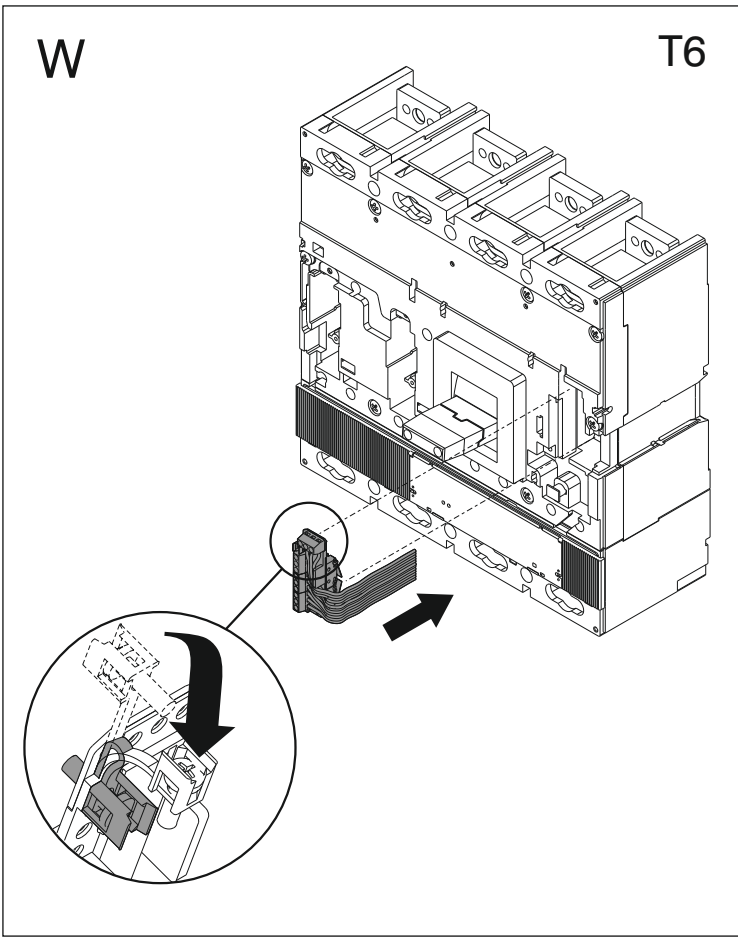

ZA

T6

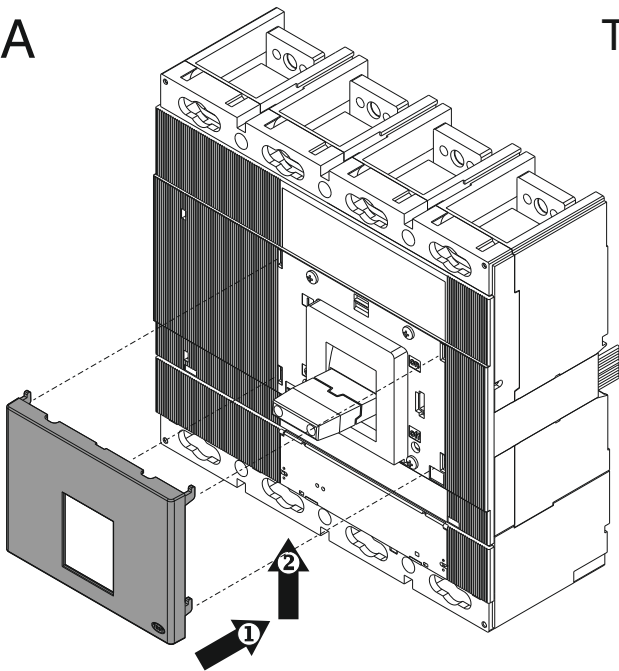

ZB

T1-T2-T3  
T4-T5-T6

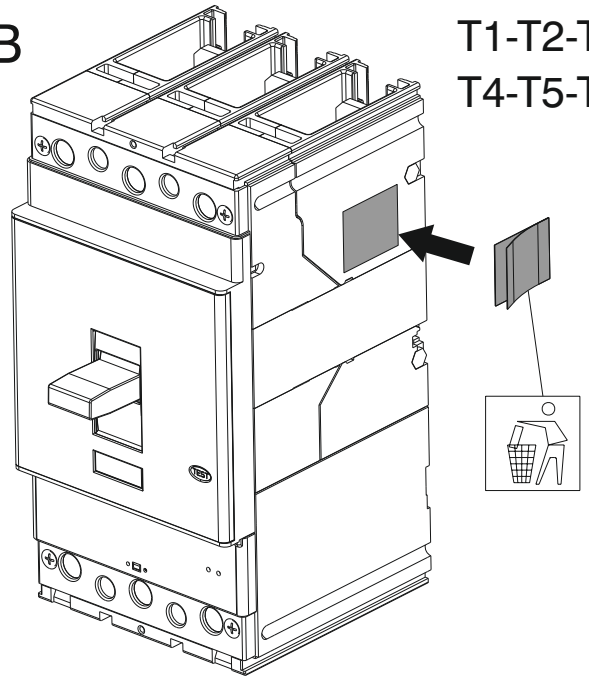

ZC

21

LEGENDA KEY ZEICHENERKLÄRUNG LÉGENDE LEYENDA  
图号说明

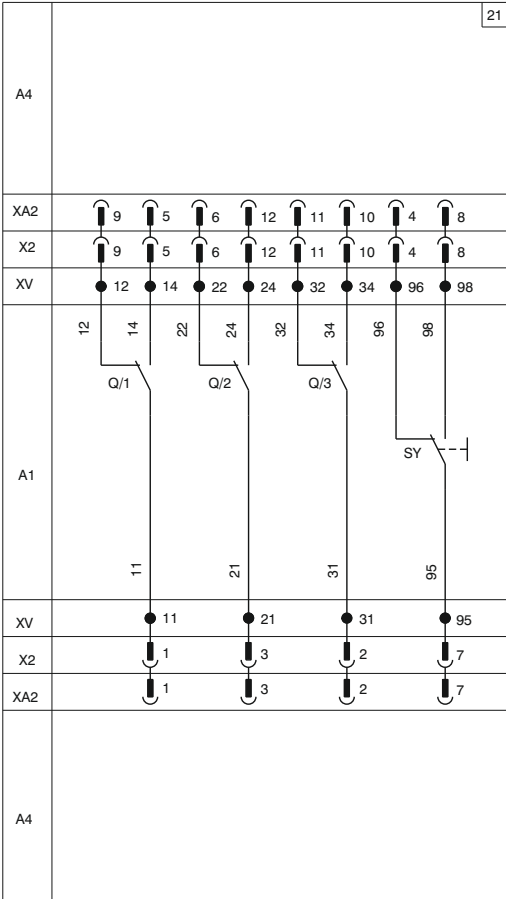

- SY = Contatto per la segnalazione elettrica di interruttore aperto per intervento degli sganciatori termomagnetici, YO, YO1, YO2, YU (posizione di scattato)
- SY = Contact for electrical signalling of circuit-breaker open due to Tripping of the thermomagnetic releases, YO, YO1, YO2, YU (tripped position)
- SY = Schalter für die elektrische Anzeige der Ausschaltung des Leistungsschalters wegen Auslösung der Thermomagnetischen Auslöser YO, YO1, YO2, YU (Ausgelöst-Stellung)
- SY = Contact pour la signalisation électrique de disjoncteur ouvert pour déclenchement des déclencheurs magnétothermiques, YO, YO1, YO2, YU (position déclenché)
- SY = Contacto para la señalización eléctrica de interruptor abierto para intervención de los relés termomagnéticos, YO, YO1, YO2, YU (posición de disparo)
- SY = 由YO, YO1, YO2或YU, 热磁脱扣器脱扣导致断路器分闸的电气信号触头
- Q/1-3 = Contatti ausiliari dell'interruttore  
Q/1-3 = Auxiliary contacts of the circuit-breaker  
Q/1-3 = Hifsschalter des Leistungsschalters  
Q/1-3 = Contacts auxiliaires du disjoncteur  
Q/1-3 = Contactos auxiliares del interruptor  
Q/1-3 = 断路器辅助触头

ZD

Part No	Type	Voltage	Current	Ratings
1SDA051369R1	(3Q+1SY)	125/250 V ac	6A	UL
		125 V ac	6A	
		250 V ac	5A	IEC
		125 V dc	0,3A	
		250 V dc	0,15A	
1SDA054914R1	(3Q+1SY)	125 V ac	0,1A	UL
		30 V dc	0,3A	IEC

